

# GRIZZLY

## OPERATOR'S INSTRUCTION MANUAL

MODEL: 225 000 / 226 000 / 227 000 ENGINE MODEL: \_\_\_\_\_

SERIAL: \_\_\_\_\_ ENGINE SERIAL: \_\_\_\_\_

DATE OF PURCHASE: \_\_\_\_\_

PURCHASED FROM: \_\_\_\_\_

**WARNING:** THIS PRODUCT IS DESIGNED AND MANUFACTURED TO PROVIDE SAFE AND DEPENDABLE SERVICE IF OPERATED ACCORDING TO INSTRUCTIONS. THE MANUFACTURER PROVIDES THE FOLLOWING INSTRUCTIONS FOR USE AND CARE OF THIS EQUIPMENT AND RELIES UPON THE PURCHASER TO SEE TO IT THAT THESE INSTRUCTIONS ARE MADE CLEAR TO THE PERSONS WHO WILL ACTUALLY BE USING THE EQUIPMENT. FAILURE TO DO SO COULD RESULT IN SERIOUS INJURY OR EQUIPMENT DAMAGE.

### **GRIZZLY EQUIPMENT**

9475 PASCAL GAGNON STREET, ST-LÉONARD, QUEBEC, CANADA

TEL: (514) 325-1260 / 1-888-325-9953 FAX: (514) 325-9952

E-MAIL: [info@alcor-inc.com](mailto:info@alcor-inc.com) Web site: [www.grizzlyequip.com](http://www.grizzlyequip.com)

**INDEX**

|                               |   |
|-------------------------------|---|
| INTRODUCTION.....             | 3 |
| PREPARATION .....             | 4 |
| OPERATOR; .....               | 4 |
| WEAR PROPER ATTIRE .....      | 4 |
| ROOF PREPARATION .....        | 4 |
| INSPECT ROOF DECK .....       | 4 |
| WARNING LINE SYSTEM.....      | 4 |
| HOISTING TO ROOF.....         | 5 |
| INSPECT THE HOIST.....        | 5 |
| LIFTING MACHINE TO ROOF ..... | 5 |
| SAFETY PRECAUTIONS .....      | 5 |
| MAINTENANCE.....              | 6 |
| OPERATION .....               | 6 |
| SAFETY HAZARDS .....          | 7 |
| Falls .....                   | 7 |
| Burns.....                    | 7 |
| Heavy Lifting .....           | 7 |
| Fire/Explosion .....          | 7 |
| Electrocution.....            | 8 |
| Falling Objects.....          | 8 |
| Flying Objects.....           | 8 |
| Unguarded Machinery .....     | 8 |
| BLOW OUT .....                | 9 |

## INTRODUCTION

### 225 000, 226 000, 227 000 TRANSPORTER

Thank you for purchasing this quality **GRIZZLY** product. With proper use and care, the transporter will provide many years of reliable service. For the safety of all job-site personnel it is mandatory that the instructions provided for the use and handling of the equipment be read and thoroughly understood by the operators.



225 000



226 000



227 000

### CAUTION

INTENDED USE; THIS MACHINE IS INTENDED TO BE USED ON FLAT, LEVEL ROOFS ONLY FOR THESE APPLICATIONS; INSULATION AND LIGHT MATERIAL CARRYING.  
ANY OTHER USE OF THIS EQUIPMENT VOIDS THE MANUFACTURER'S WARRANTY AND IS THE SOLE RESPONSIBILITY OF THE OWNER/USER, SHOULD ANY DAMAGE OR INJURY OCCUR.

## **PREPARATION**

### **OPERATOR:**

START BY READING AND FULLY UNDERSTANDING OPERATING INSTRUCTIONS. IF SOMETHING IS NOT UNDERSTOOD, HAVE SOMEONE ELSE READ AND EXPLAIN THE INSTRUCTIONS TO THE OPERATOR OR CALL THE MANUFACTURER FOR INFORMATION. AN UNINFORMED OPERATOR CAN SUBJECT HIMSELF AND OTHERS TO DEATH OR SERIOUS INJURY.

## **WEAR PROPER ATTIRE**

Safety glasses are recommended and must be worn if any roof cutting or scraping is being done in the vicinity. Safety glasses and or face shield are also necessary when working with hot stuff.

Wear properly fitting clothes. Tight clothing can restrict movement and slow down reaction time in a dangerous situation. Loose fitting clothing can be dangerous and cause serious injury if it gets caught in moving mechanical parts. Wear a long-sleeved shirt, buttoned at the cuffs, safety shoes, and pants without cuffs, and knit wrist type gloves.

A hard hat must be worn by operator when working on a job site.

## **ROOF PREPARATION**

### **INSPECT ROOF DECK**

Before allowing equipment and personnel access to roof, make certain roof is strong enough to support the weight. Check load limits of deck with owner, builder or architect. Clear the work area of all potentially dangerous obstacles that could cause personal injury to the operator or others. Keep unauthorized people away from construction area. Check to see that all roof openings are guarded to protect against falls.

### **WARNING LINE SYSTEM**

When operating parallel to roof edge warning line system must be at least six feet from edge. When operating perpendicular to edge warning line must be ten feet from roof edge.

## HOISTING TO ROOF

**WARNING;** ALWAYS CHECK DECK LOAD LIMITS WITH BUILDER, OWNER, OR ARCHITECT BEFORE DECIDING TO USE ON THE ROOF.

### INSPECT THE HOIST

Make certain hoist is in safe operating condition, to be operated by trained personnel. The hoist should be clear of ground objects and overhead obstacles, such as power lines; it should be secure and properly counterbalanced. Hoist should be inspected for frayed cables, bent frame members or faulty mechanical parts. Make sure everyone on the ground is completely clear of the hoisting area. Do not exceed the weight and size capacity of your hoist. Do not use if you are in doubt.

### LIFTING MACHINE TO ROOF

Lift rings are not provided on this machine; lift the transporter by firmly securing cable or sling around the machine's frame. Always make sure the hoist, cable, hook, etc. are in good running order or damage or injury may result.

|                |  |                |
|----------------|--|----------------|
| <b>WEIGHT:</b> | 225 000 Transporter with swivel rear wheels          | <b>145 LBS</b> |
|                | 226 000 Transporter with 400 X 8 rear wheels (fixed) | <b>140 LBS</b> |
|                | 227 000 Transporter without rear wheels              | <b>110 LBS</b> |

## SAFETY PRECAUTIONS

- Never operate equipment that is damaged in any way. Repairs or replacement of damaged components must be made by a qualified mechanic
- Do not modify the equipment. Do not operate a modified piece of equipment.
- Avoid slick areas on the roof to prevent slipping.
- Wear safety footwear and snug fit clothing.
- Be trained to do the specific job before operating the equipment on an actual job.
- Do not exceed weight carrying capacity of the deck. Check with owner or architect for deck capacity.
- Use on flat, level roofs only.
- Guard all openings in the roof.
- Do not operate within 10 feet of roof edge (or within 6 feet, if operation is parallel to the edge.)
- Do not operate this machine if you are under the influence of alcohol, marijuana, or drugs that could impair judgment and ability.
- Keep the equipment in good condition.

## MAINTENANCE

Lubrication recommendations are as follows: roller bearings on wheels should be greased weekly or as needed.

All parts should be inspected on a regular basis, and replaced as necessary. This includes tires, rollers or structural parts of the transporter.

Replace broken parts before operating.

Tire Servicing: Check tire pressure on tires.

Always check tire manufacturer's recommendations for correct tire pressure before inflating tire. (Correct tire pressure should be imprinted on the side of the tire.)

## **OPERATION**

The 225 000, 226 000 and 227 000 Transporters are designed for the use inside a perimeter warning system. They are a tilt and push/pull type machine. Do not operate within 10 feet of roof edge (or 6 feet if operating parallel to roof). Keep well clear of other people and materials on the roof while operating.

The Transporter is designed for insulation and light material carrying. It is a typical tilt and push/pull type machine and operator must respect this. Large capacity makes every trip count. The Transporter's wide wheel design makes it extremely stable with large loads. Heavy tubular steel frame will last for years and the built in sliding rear wheel support allows the machine to be tilted back and used as a trailer.

Care must be taken when lifting heavy loads.

The proper lifting techniques described below can minimize the stress on your muscles and spine.

- Plan your move, size up the load and make sure your path is clear.
- Use a wide-balanced stance with one foot slightly ahead of the other.
- Tighten your stomach muscles as the tilt begins.
- Lower the load slowly.
- Make sure you don't roll and walk over debris.
- If you are pulling the machine, make sure you are looking in the direction you are going. Never back up near an opening on the roof or near the roof edge.
- **Do not run with the transporter, serious injury can occur.**

After reading through all of the instructions, the 225 000, 226 000 and 227 000 Transporter should be ready for operation. When operating equipment for the first time, position the equipment on the ground or in an open level area away from obstructions and roof edges. With no load on the transporter, practice manoeuvring the equipment.

## **SAFETY HAZARDS**

Safety hazards are not always obvious to workers. Unlike exposure to health hazards, where illness or injury develop slowly, safety hazards usually result in immediate injury or death.

Broken bones, cuts bruises, sprains, burns and loss of limbs, eyesight and hearing are the kinds of injuries caused by safety hazards.

The rate of occupational injuries in roofing, in fact, ranks in the top ten of all major occupational groups.

### **Falls**

Falls are the number one cause of serious injury and death to roofers. An estimated 10 percent of all roofing accidents result from falls off roof edges, through roofing openings or off ladders, more than half of the non-fatal accidents result in serious injury.

Unprotected and unguarded roof edges and roof openings create extremely hazardous conditions.

Ladders with cracked, loose or missing steps: with side rails broken or cracked and not attached firmly to the steps; with broken, loose or missing locks, or coated with grease, oils or hardened bitumen can lead to serious injury. Ladders should always be inspected to make sure they're properly maintained and constructed and that they're long enough to extend three feet above the roof's surface.

Improperly balanced or unstable hoists overturn and will often carry the worker along. Rolls of roofing felt should never be used as counterweight. Workers should know the load capacity; it should be posted.

### **Burns**

Skin contact with hot asphalt and hot coal tar pitch usually results in second and third degree burns. They usually involve deeper portions of the skin and are easily infected.

An estimated 16 percent of all injuries are burns from hot stuff. The major causes of burns have been from:

Kettle flashes

- ▶ Kettle splashes from dropping pieces of coal pitch or asphalt into the kettle
- ▶ Slips and trips while carrying hot bitumen in open containers
- ▶ Splashes involving transfer operations like from the hot pipe outlet to a hot lugger, from a hot lugger to a mop cart or a pail, or from the kettle to a pail.

### **Heavy Lifting**

Sprains and strains, a majority of which involve the back, are the most common roofing injury and one of the most severe. Almost 30 percent of these injuries result in 10 or more days away from work.

### **Fire/Explosion**

Two conditions must be met in order for fires and explosions to occur. First, there must be an ignition source, a welding arc, spark, cigarette, flame or simply a hot spot as in a kettle or tanker. Secondly, there must be the right mixture of vapours (from asphalt, pitch, solvents) and oxygen.

For kettles and tankers, fire/explosion conditions arise when:

- ▶ oversized burners are used to fire the kettle, causing localized overheating of the heating tubes creating a hot spot
- ▶ the temperature of the bitumen is brought up to the desired operation temperature too quickly allowing the level of bitumen to drop to the level of the firing tubes, allowing excessively high surface temperatures
- ▶ heating the bitumen to its flash point (for asphalt, about 525°-540°; for pitch, about 450°-475°)
- ▶ the temperature of the bitumen is hot enough to reach the auto-ignition level
- ▶ in tankers, the vent pipe is clogged or plugged so that flammable vapours can build up to explosive levels

Many solvents evaporate quickly at roof temperatures. Explosive mixtures of vapours can be readily formed within confined spaces like high parapet walls, in atriums or in any space where little or no ventilation exists. And any kind of spark or flame can ignite the vapours.

### **Electrocution**

Low voltage electricity can cause shock, muscle contractions, breathing difficulty, irregular heartbeat, severe burns and death. The route that the current takes through the body affects the degree of injury. Current flowing from one finger to another would not pass vital organ, while from one hand to another would pass through the heart and lungs.

Electrical tools should be properly grounded. The electrical cord should end in a three-prong grounding contact, or the wires should be enclosed in a metal case with a special grounding attachment.

Employers are required to provide ground fault circuit interrupters for all outlets on construction sites that are not part of the permanent wiring of the building. This is actually a fast-acting circuit breaker, which can shut off electricity in a fraction of a second.

Aluminum or other metal ladders pose a serious electrical hazard around electrical equipment and energized lines.

### **Falling Objects**

Tools, bricks, materials, buckets, boxes, pallets or almost anything dropped from a sufficient height can cause severe damage. Head injuries, one of the highest compensated injuries to workers, often include brain damage.

Workers need protective head gear when working beneath people, tools and equipment.

### **Flying Objects**

Objects can be projected by machines, from welding or grinding operations and can be windblown. Tear-off operations, where power cutters, power brooms and power spudders are generally used, are the major source of flying substances. The part of the body most often injured is the eyes.

### **Unguarded Machinery**

Exposed blades and chains on powered machinery like hoists and roof cutters can severely lacerate and crush parts of the body. Guards should always be fitted over moving parts to protect workers.



**BLOW OUT**

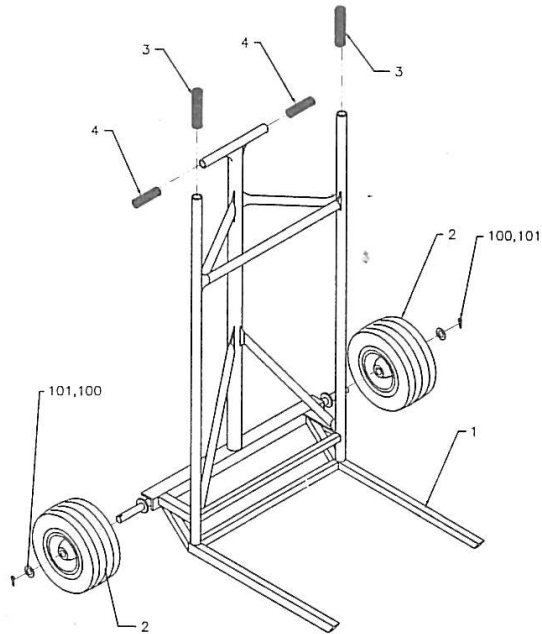

| ITEM | NO.    | QTY. | DESCRIPTION |
|------|--------|------|-------------|
| 1    | 227001 | 1    | FRAME       |
| 2    | 935006 | 2    | WHEEL, REAR |
| 3    | 940007 | 2    | HANDLE GRIP |
| 4    | 940005 | 2    | HANDLE GRIP |
| 100  | 914755 | 2    | COTTER PIN  |
| 101  | 912021 | 2    | WASHER      |

|  |             |
|--|-------------|
| DATE: 07.07.1998                         | TRANSPORTER |
| REV.: 01.01.2005                         |             |
| EQUIPMENT<br><b>GRIZZLY</b><br>EQUIPMENT | 227000      |

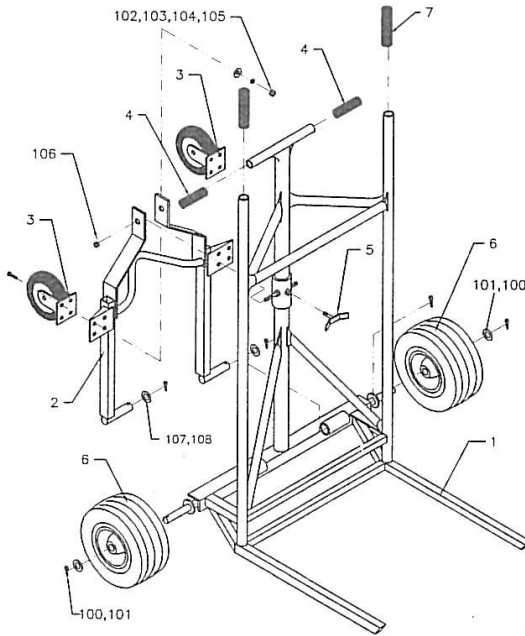

| ITEM | NO.    | QTY. | DESCRIPTION         |
|------|--------|------|---------------------|
| 1    | 225001 | 1    | FRAME               |
| 2    | 225002 | 1    | WHEEL SUPPORT ASSY. |
| 3    | 935051 | 2    | WHEEL, FRONT        |
| 4    | 940005 | 2    | HANDLE GRIP         |
| 5    | 900008 | 1    | LOCK SCREW          |
| 6    | 935006 | 2    | WHEEL, REAR         |
| 7    | 940007 | 2    | HANDLE GRIP         |
| 100  | 914755 | 4    | COTTER PIN          |
| 101  | 912021 | 4    | WASHER              |
| 102  | 912003 | 8    | WASHER              |
| 103  | 913007 | 8    | NUT, HEX            |
| 104  | 910152 | 8    | BOLT, HEX           |
| 105  | 912503 | 8    | LOCK-WASHER         |
| 106  | 913511 | 2    | LOCK-NUT            |
| 107  | 912023 | 2    | WASHER              |
| 108  | 914703 | 2    | COTTER PIN          |

|  |             |
|--|-------------|
| DATE: 07.07.1998                         | TRANSPORTER |
| REV.: 01.01.2005                         |             |
| EQUIPMENT<br><b>GRIZZLY</b><br>EQUIPMENT | 225000      |

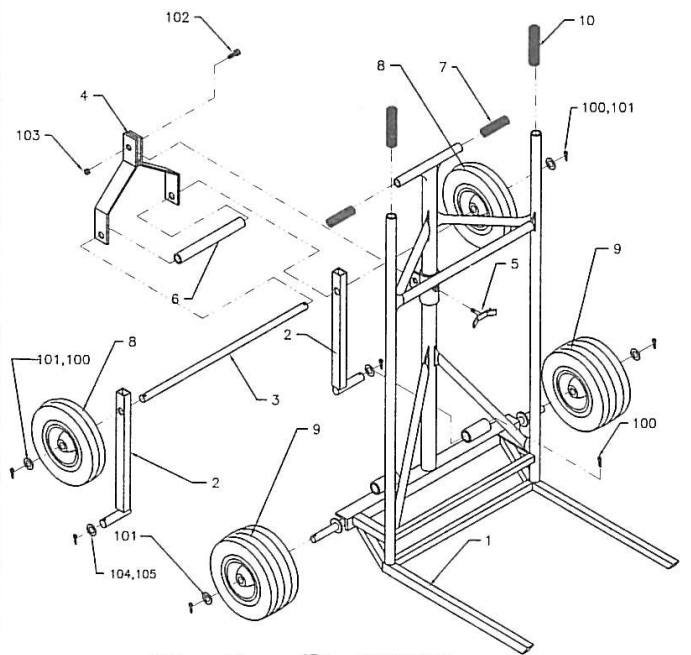

| ITEM | NO.    | QTY. | DESCRIPTION   |
|------|--------|------|---------------|
| 1    | 226001 | 1    | FRAME         |
| 2    | 226002 | 2    | WHEEL SUPPORT |
| 3    | 226003 | 1    | WHEEL SHAFT   |
| 4    | 226004 | 1    | WHEEL FORK    |
| 5    | 900008 | 1    | LOCK SCREW    |
| 6    | 226006 | 1    | SPACER        |
| 7    | 940005 | 2    | HANDLE GRIP   |
| 8    | 935009 | 2    | WHEEL, REAR   |
| 9    | 935006 | 2    | WHEEL, FRONT  |
| 10   | 940007 | 2    | HANDLE GRIP   |
| 100  | 914755 | 6    | COTTER PIN    |
| 101  | 912021 | 4    | WASHER        |
| 102  | 910253 | 1    | BOLT, HEX.    |
| 103  | 913511 | 1    | LOCK-NUT      |
| 104  | 912023 | 2    | WASHER        |
| 105  | 914703 | 2    | COTTER PIN    |

|  |             |
|--|-------------|
| DATE: 07.07.1998                         | TRANSPORTER |
| REV.: 01.01.2005                         |             |
| EQUIPMENT<br><b>GRIZZLY</b><br>EQUIPMENT | 226000      |