

# GRIZZLY™ EQUIPMENT

## G SERIES

G41 AND ATTACHMENTS



THE LIGHTEST MINISKID AVAILABLE



**GRIZZLY™**

[WWW.GRIZZLYEQUIP.COM](http://WWW.GRIZZLYEQUIP.COM)

GRIZZLY EQUIPMENT IS A TRADEMARK OF ALCOR INC.

# GRIZZLY™ EQUIPMENT

## 410 000 - G41

How about a machine that can pick-up, push, sweep, tear-off, carry, move, dump, lift, dig, etc... and do it safely with minimal maintenance.

The G41 is the lightest machine in its class, while being very powerful. Its CH20S Kohler engine offers tons of torque and a 2 year commercial warranty.



It is also equipped with a universal attachment adaptor that allows the use of dozens of accessories.

The G41 features 4 independent hydraulic wheel motors that require no chains, and therefore no adjustments nor tensioning of these chains, eliminating the lag from loose chains. The controls keep their precision and the operator keeps working, reducing down time.

Safety is enhanced by placing the operator on a platform at the back of the machine, allowing the operator to "Step-off" in case on an emergency.

The operator's feet are also protected from the machine's moving wheels and ergonomic levers permit comfortable and precise use of the controls.

This configuration also keeps the bucket away from the operator, keeping falling debris away from the operator's hands and head.

Maintenance is made easy by putting everything within reach.

**Weight:** 1190 lbs

**With bucket:** 1310 lbs



**GRIZZLY™**  
www.GRIZZLYEQUIP.COM  
888-325-9953

GRIZZLY EQUIPMENT IS A TRADEMARK OF ALCOR INC.

The manufacturer reserves the right to change specifications and designs without notice

# GRIZZLY™ EQUIPMENT

## 410 000 - G41

This machine was designed with exceptional access to all components for ease of maintenance, all fittings, hoses, filters, etc. are accessible from the top, the sides or the back.

4 independent wheel motors, no chains, no adjustments, no lag in the operation of the controls due to loose chains, this is a real 4 wheel drive.

CH20S Kohler engine with tons of torque and 2 year commercial warranty!

Removable dash for easy access to fittings and components.

Master valve contains a float on the lift section as a standard.

Auxiliary valve with flow control to allow 0-12 GPM adjustment.

Standard hour meter with reset and RPM.

Large capacity gasoline tank, 30L (8 gal.) for prolonged working periods and removable for those times when emptying is required.

Removable lateral storage box.

Cylinder lock bar to allow safe maintenance of the machine under the arms.

Flat bottom so going over obstruction, won't snag or damage hydraulic hoses or other components.

Universal attachment adaptor and flat face quick couplers allow the use of dozens of accessories.

4 lifting rings to lift and/or secure the machine.

Many different styles of wheels available as options.

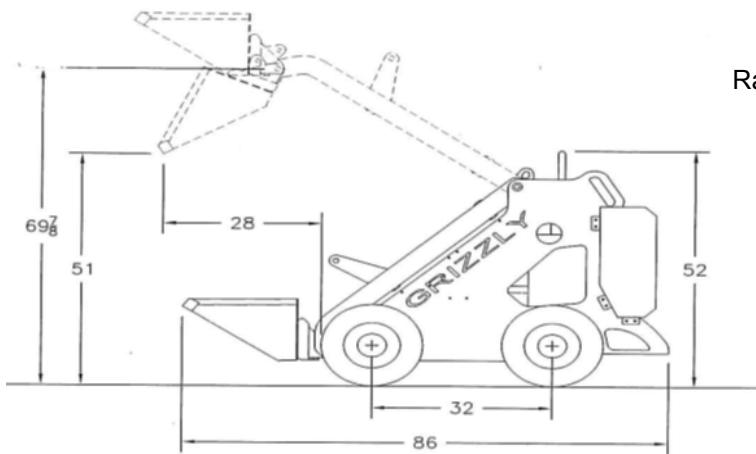

Tipping capacity: 1000 lbs  
Rated operating capacity: 500 lbs (50% of tipping capacity)

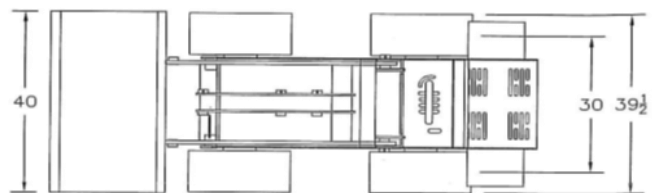

Optional wheels



**GRIZZLY™**  
www.GRIZZLYEQUIP.COM  
888-325-9953

GRIZZLY EQUIPMENT IS A TRADEMARK OF ALCOR INC.

The manufacturer reserves the right to change specifications and designs without notice

# GRIZZLY™ EQUIPMENT

## 411 000 - DUAL WHEEL KIT



This dual wheel kit is EASY ON, EASY OFF! This simple option allows the weight of this already light machine to be spread over eight wheels allowing it to work over soft or fragile surfaces with more confidence. Operator is ultimately responsible for working on any surface and must proceed with care.

This kit is comprised of 4 regular wheels #935024, 4 hubs #411001 and 20 wheel nuts.



**GRIZZLY™**  
WWW.GRIZZLYEQUIP.COM  
888-325-9953

GRIZZLY EQUIPMENT IS A TRADEMARK OF ALCOR INC.

The manufacturer reserves the right to change specifications and designs without notice

# GRIZZLY™ EQUIPMENT

## 412 000 - HYDRAULIC SWEEPER



This 44" sweeper allows you to sweep forward, to the left or to the right depending on your needs.

The brush rotation speed is adjustable. A high rotation speed will be used to throw debris and snow a fair distance or a slower speed will be used when keeping debris like stones and rubble closer to the brush is important.

- Quick couplers
- 3 sweeping positions
- Poly/wire brush



**WEIGHT : 210 LBS**



**GRIZZLY™**  
www.GRIZZLYEQUIP.COM  
888-325-9953

GRIZZLY EQUIPMENT IS A TRADEMARK OF ALCOR INC.

The manufacturer reserves the right to change specifications and designs without notice

# GRIZZLY™ EQUIPMENT

## 413 000 - ROOF REMOVER



This roof remover attachment will lift the old material over its back plate to allow the material to be picked up at a more comfortable height, to be discarded into trailer or workhorse.

**WEIGHT : 140 LBS**



**GRIZZLY™**  
www.GRIZZLYEQUIP.com  
888-325-9953

GRIZZLY EQUIPMENT IS A TRADEMARK OF ALCOR INC.

The manufacturer reserves the right to change specifications and designs without notice

# GRIZZLY™ EQUIPMENT

## 414 000 - FORK



An interesting addition to your G41

An efficient way to transfer skids of light material, rolls, bundles or whatever can be loaded onto or picked up by these forks.

Forks slide side to side to adjust to your needs.

Back guard is removable.

May lift up to 500 lbs.



**WEIGHT : 140 LBS**



**GRIZZLY™**  
www.GRIZZLYEQUIP.COM  
888-325-9953

GRIZZLY EQUIPMENT IS A TRADEMARK OF ALCOR INC.

The manufacturer reserves the right to change specifications and designs without notice