

# GRIZZLY

## OPERATOR'S INSTRUCTION MANUAL

MODEL: 340 000 ENGINE MODEL: \_\_\_\_\_

SERIAL: \_\_\_\_\_ ENGINE SERIAL: \_\_\_\_\_

DATE OF PURCHASE: \_\_\_\_\_

PURCHASED FROM: \_\_\_\_\_

**WARNING:** THIS PRODUCT IS DESIGNED AND MANUFACTURED TO PROVIDE SAFE AND DEPENDABLE SERVICE IF OPERATED ACCORDING TO INSTRUCTIONS. THE MANUFACTURER PROVIDES THE FOLLOWING INSTRUCTIONS FOR USE AND CARE OF THIS EQUIPMENT AND RELIES UPON THE PURCHASER TO SEE TO IT THAT THESE INSTRUCTIONS ARE MADE CLEAR TO THE PERSONS WHO WILL ACTUALLY BE USING THE EQUIPMENT. FAILURE TO DO SO COULD RESULT IN SERIOUS INJURY OR EQUIPMENT DAMAGE.

### **GRIZZLY EQUIPMENT**

9475 PASCAL GAGNON STREET, ST-LÉONARD, QUEBEC, CANADA

TEL: (514) 325-1260 / 1-888-325-9953 FAX: (514) 325-9952

E-MAIL: [info@alcor-inc.com](mailto:info@alcor-inc.com) Web site: [www.grizzlyequip.com](http://www.grizzlyequip.com)

**INDEX**

INTRODUCTION.....	3
PREPARATION .....	4
OPERATOR; .....	4
WEAR PROPER ATTIRE .....	4
ROOF PREPARATION .....	4
INSPECT ROOF DECK .....	4
WARNING LINE SYSTEM.....	4
HOISTING TO ROOF.....	5
INSPECT THE HOIST.....	5
CONNECTING TO LIFT RINGS .....	5
SAFETY PRECAUTIONS .....	6
OPERATION .....	7
Before Operation .....	7
Engine Start-Up Operation .....	7
The Controls.....	8
ATTACHMENTS .....	9
MAINTENANCE.....	10
SAFETY HAZARDS .....	11
Falls .....	11
Burns .....	11
Heavy Lifting .....	11
Fire/Explosion .....	11
Electrocution.....	12
Falling Objects.....	12
Flying Objects.....	12
Unguarded Machinery .....	12
BLOW OUT .....	13

## INTRODUCTION

### 340 000 PREDATOR

Thank you for purchasing this quality **GRIZZLY** product. With proper use and care the Predator will provide many years of reliable service. For the safety of all job-site personnel it is mandatory that the instructions provided for the use and handling of the equipment be read and thoroughly understood by the operators.



### CAUTION

**INTENDED USE;** THIS MACHINE IS INTENDED TO BE USED ON FLAT, LEVEL ROOFS ONLY. IT IS INTENDED TO USE ONLY THE ATTACHMENTS MADE SPECIFICALLY FOR IT BY GRIZZLY AND TO PERFORM THE TASKS THOSE ATTACHMENTS MAY PERMIT. SUCH AS TRANSPORTING GRAVEL, DEBRIS, DIRT, INSULATION, ROLLS, ETC. ETC. ANY OTHER USE OF THIS EQUIPMENT VOIDS THE MANUFACTURER'S WARRANTY AND IS THE SOLE RESPONSIBILITY OF THE OWNER/USER, SHOULD ANY DAMAGE OR INJURY OCCUR.

## **PREPARATION**

### **OPERATOR:**

START BY READING AND FULLY UNDERSTANDING OPERATING INSTRUCTIONS. IF SOMETHING IS NOT UNDERSTOOD, HAVE SOMEONE ELSE READ AND EXPLAIN THE INSTRUCTIONS TO THE OPERATOR OR CALL THE MANUFACTURER FOR INFORMATION. AN UNINFORMED OPERATOR CAN SUBJECT HIMSELF AND OTHERS TO DEATH OR SERIOUS INJURY.

## **WEAR PROPER ATTIRE**

Safety glasses are recommended and must be worn if any roof cutting or scraping is being done in the vicinity. Safety glasses and or face shield are also necessary when working with hot stuff.

Wear properly fitting clothes. Tight clothing can restrict movement and slow down reaction time in a dangerous situation. Loose fitting clothing can be dangerous and cause serious injury if it gets caught in moving mechanical parts. Wear a long-sleeved shirt, buttoned at the cuffs, safety shoes, and pants without cuffs, and knit wrist type gloves.

A hard hat must be worn by operator when working on a job site.

## **ROOF PREPARATION**

### **INSPECT ROOF DECK**

Before allowing equipment and personnel access to roof, make certain roof is strong enough to support the weight. Check load limits of deck with owner, builder or architect. Clear the work area of all potentially dangerous obstacles that could cause personal injury to the operator or others. Keep unauthorized people away from construction area. Check to see that all roof openings are guarded to protect against falls.

### **WARNING LINE SYSTEM**

When operating parallel to roof edge warning line system must be at least six feet from edge. When operating perpendicular to edge warning line must be ten feet from roof edge.

## HOISTING TO ROOF

**WARNING;** ALWAYS CHECK DECK LOAD LIMITS WITH BUILDER, OWNER, OR ARCHITECT BEFORE DECIDING TO USE ON THE ROOF.

### INSPECT THE HOIST

Make certain hoist is in safe operating condition, to be operated by trained personnel. The hoist should be clear of ground objects and overhead obstacles, such as power lines; it should be secure and properly counterbalanced. Hoist should be inspected for frayed cables, bent frame members or faulty mechanical parts. Make sure everyone on the ground is completely clear of the hoisting area. Do not exceed the weight and size capacity of your hoist. Do not use if you are in doubt.

### CONNECTING TO LIFT RINGS

There is a sling provided with the predator (sling #340100). Always lift machine by the ring in the sling (see Fig. 2). Before lifting, inspect shackles and cable for damage, wear and tightness. Do not attempt to lift the machine by any other part. Make sure the hoist, cable, hook, etc. are in good running order, or damage or injury may result.



**Fig. 2**

<b>WEIGHT:</b>	340 000 Predator	<b>260 LBS</b>
	340 400 Platform with swivel wheels	<b>110 LBS</b>
	340 500 Gravel dispenser	<b>150 LBS</b>
	340 700 Dump Tray	<b>95 LBS</b>
	340 800 30'' Deep Tray	<b>70 LBS</b>

## SAFETY PRECAUTIONS

- Do not allow other people to be near the machine during operation (except operator)
- Never carry or transport people with this machine.
- Be certain all guards, shields and pins are secure and locked before starting.
- Never operate a workhorse that is damaged in any way. Repairs or replacement of damaged components must be made by a qualified mechanic
- Do not modify the equipment. Do not operate a modified piece of equipment.
- Never reach into the belt area when the engine is operating, keep hands and feet away from the brake, belts and the chains.
- Wear safety footwear, eye protection and snug fit clothing.
- Operate the Workhorse only from the “Walk Behind” position.
- Operate on flat, level roofs only.
- Use only **GRIZZLY** attachments.
- Keep away from electrical lines.
- Use caution when handling fuel. Gasoline is very flammable. Shut off engine, and allow cooling before refuelling. Clean up gasoline before restarting.
- Guard all openings on the roof.
- Do not allow anyone to walk in front of the Predator.
- Do not operate within 10 feet of roof edge (or within 6 feet, if operating parallel to the edge).
- Try to operate machine in such a way that you are always walking forward.
- Do not operate this machine if you are under the influence of alcohol, marijuana, or drugs that could impair judgment and ability.
- Keep the equipment in good condition.
- Never carry objects that may restrict or obstruct your vision.
- The owner or operator must see that all warning decals are in place and legible. Write to **GRIZZLY** Equipment for replacement decals and instructions.

## OPERATION

### Before Operation

Check to see that engine is serviced properly. Read Honda operation and safety instructions. Handle gasoline with extreme caution. Make certain belt guards and blade guards are in place and secure and that there are no signs of damage or wear of these parts. Never operate machine with damaged or missing guards. Serious injury may otherwise result.

### Engine Start-Up Operation

Make sure the clutch and brake levers aren't being pulled back (held) against the handle bar (pulling on the brake lever will release the brake and pulling on the clutch lever will release the brake and engage the clutch) (See Fig. 3)



**Fig. 3** Levers in brake on, clutch disengaged position

At this point, after you have read through all of the instructions, the Predator should be ready for operation.

Start the engine and allow to warm up. (Please refer to the engine manufacturer's owner's manual). Inspect the machine and attachments for damage, make sure attachments are well anchored to the predator. When engine reaches operating temperature, pull back on the brake lever (right hand) to release the brake and pull back on the clutch lever (left hand) to engage the clutch. Adjust speed by pushing or pulling on the throttle control, always reduce speed when attempting to turn. This machine is equipped with a dead-man style brake. You can come to an immediate stop by releasing the handles. Always turn engine off when loading, unloading or dumping. Never keep levers engaged by attaching them to the handlebars by any means. This would render the safety features of the dead-man brake useless and could cause injury or death.

## The Controls

The clutch lever is on the left hand side of the handlebar (see Fig. 4) The brake and the throttle control are on the right hand side of the handlebar (see Fig. 5)

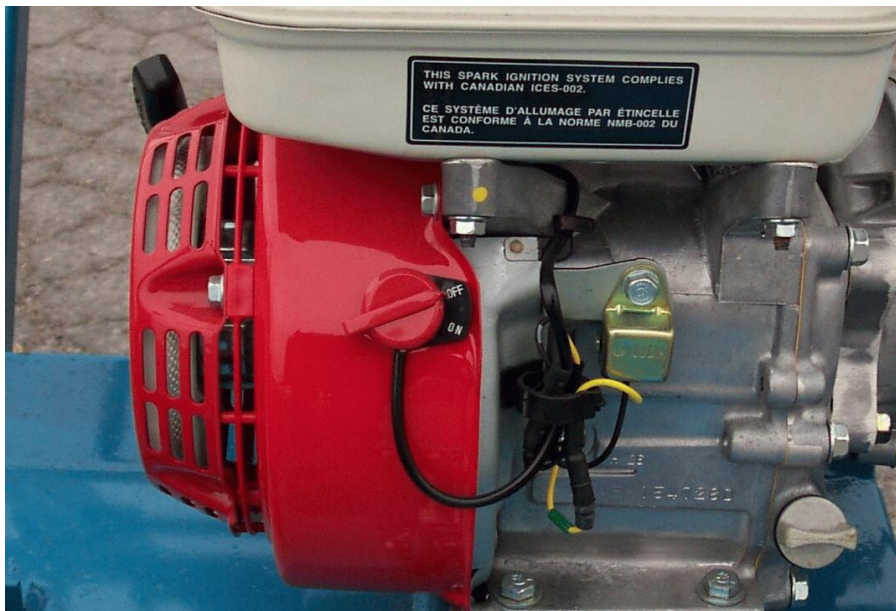

**Fig. 4**



**Fig. 5**

The on/off switch is located on the back side of the Honda engine (see Fig. 6). Be sure to test the shut-off switch before depending on it.



**Fig. 6**



## ATTACHMENTS



**#340 400 Platform**



**#340 700 Dump tray**



**Fig. 7 Hot stuff tank attachment**



**340 500 Gravel dispenser**

Install channel irons, tank and rods as shown in Fig. 7  
(Refer to operation section on use of hot tanks)

## MAINTENANCE

**CAUTION; Disconnect spark plug wire before working on machine.**

- Grease the bearings and chain regularly as needed.
- Check belt, brake band and chain, replace as needed.
- Adjust clutch and brake band by removing hitch pin from lever and turning clutch rod or brake rod clockwise to desired position.
- Check bolts and nuts for tightness.
- Clean and/or wash engine frequently to keep engine “breathing” and cooling properly.
- Follow engine manufacturer’s recommendations on engine maintenance.
- If service or repair of engine is needed, contact an authorized Honda service centre.
- Always check tire manufacturer’s recommendations for correct tire pressure before inflating tire. (Correct tire pressure should be imprinted on the side of the tire.)

## **SAFETY HAZARDS**

Safety hazards are not always obvious to workers. Unlike exposure to health hazards, where illness or injury develop slowly, safety hazards usually result in immediate injury or death.

Broken bones, cuts bruises, sprains, burns and loss of limbs, eyesight and hearing are the kinds of injuries caused by safety hazards.

The rate of occupational injuries in roofing, in fact, ranks in the top ten of all major occupational groups.

### **Falls**

Falls are the number one cause of serious injury and death to roofers. An estimated 10 percent of all roofing accidents result from falls off roof edges, through roofing openings or off ladders, more than half of the non-fatal accidents result in serious injury.

Unprotected and unguarded roof edges and roof openings create extremely hazardous conditions.

Ladders with cracked, loose or missing steps: with side rails broken or cracked and not attached firmly to the steps; with broken, loose or missing locks, or coated with grease, oils or hardened bitumen can lead to serious injury. Ladders should always be inspected to make sure they're properly maintained and constructed and that they're long enough to extend three feet above the roof's surface.

Improperly balanced or unstable hoists overturn and will often carry the worker along. Rolls of roofing felt should never be used as counterweight. Workers should know the load capacity; it should be posted.

### **Burns**

Skin contact with hot asphalt and hot coal tar pitch usually results in second and third degree burns. They usually involve deeper portions of the skin and are easily infected.

An estimated 16 percent of all injuries are burns from hot stuff. The major causes of burns have been from:

Kettle flashes

- ▶ Kettle splashes from dropping pieces of coal pitch or asphalt into the kettle
- ▶ Slips and trips while carrying hot bitumen in open containers
- ▶ Splashes involving transfer operations like from the hot pipe outlet to a hot lugger, from a hot lugger to a mop cart or a pail, or from the kettle to a pail.

### **Heavy Lifting**

Sprains and strains, a majority of which involve the back, are the most common roofing injury and one of the most severe. Almost 30 percent of these injuries result in 10 or more days away from work.

### **Fire/Explosion**

Two conditions must be met in order for fires and explosions to occur. First, there must be an ignition source, a welding arc, spark, cigarette, flame or simply a hot spot as in a kettle or tanker. Secondly, there must be the right mixture of vapours (from asphalt, pitch, solvents) and oxygen.

For kettles and tankers, fire/explosion conditions arise when:

- ▶ oversized burners are used to fire the kettle, causing localized overheating of the heating tubes creating a hot spot
- ▶ the temperature of the bitumen is brought up to the desired operation temperature too quickly allowing the level of bitumen to drop to the level of the firing tubes, allowing excessively high surface temperatures
- ▶ heating the bitumen to its flash point (for asphalt, about 525°-540°; for pitch, about 450°-475°)
- ▶ the temperature of the bitumen is hot enough to reach the auto-ignition level
- ▶ in tankers, the vent pipe is clogged or plugged so that flammable vapours can build up to explosive levels

Many solvents evaporate quickly at roof temperatures. Explosive mixtures of vapours can be readily formed within confined spaces like high parapet walls, in atriums or in any space where little or no ventilation exists. And any kind of spark or flame can ignite the vapours.

### **Electrocution**

Low voltage electricity can cause shock, muscle contractions, breathing difficulty, irregular heartbeat, severe burns and death. The route that the current takes through the body affects the degree of injury. Current flowing from one finger to another would not pass vital organ, while from one hand to another would pass through the heart and lungs.

Electrical tools should be properly grounded. The electrical cord should end in a three-prong grounding contact, or the wires should be enclosed in a metal case with a special grounding attachment.

Employers are required to provide ground fault circuit interrupters for all outlets on construction sites that are not part of the permanent wiring of the building. This is actually a fast-acting circuit breaker, which can shut off electricity in a fraction of a second.

Aluminum or other metal ladders pose a serious electrical hazard around electrical equipment and energized lines.

### **Falling Objects**

Tools, bricks, materials, buckets, boxes, pallets or almost anything dropped from a sufficient height can cause severe damage. Head injuries, one of the highest compensated injuries to workers, often include brain damage.

Workers need protective head gear when working beneath people, tools and equipment.

### **Flying Objects**

Objects can be projected by machines, from welding or grinding operations and can be windblown. Tear-off operations, where power cutters, power brooms and power spudders are generally used, are the major source of flying substances. The part of the body most often injured is the eyes.

### **Unguarded Machinery**

Exposed blades and chains on powered machinery like hoists and roof cutters can severely lacerate and crush parts of the body. Guards should always be fitted over moving parts to protect workers.

**BLOW OUT**

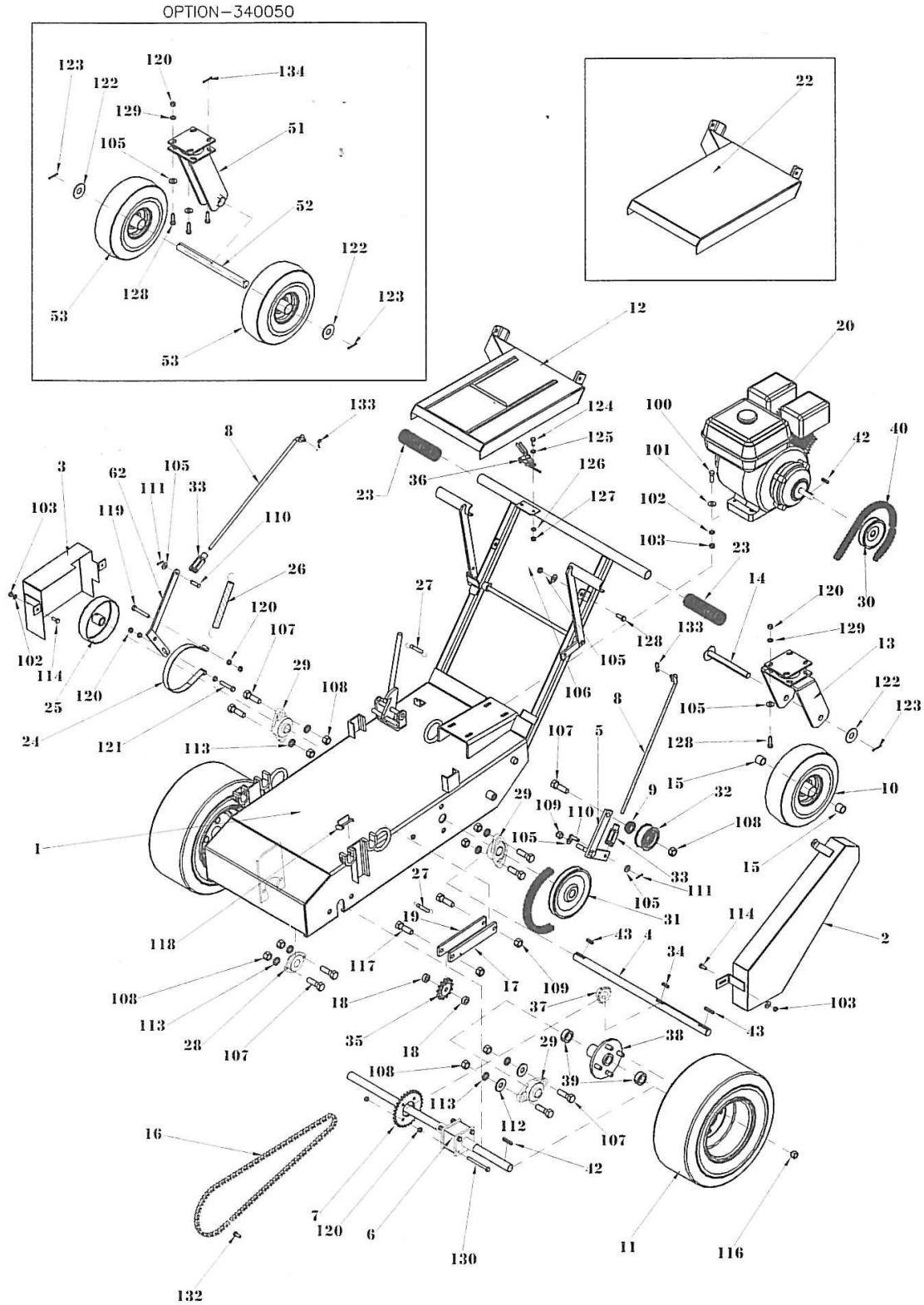

DATE:	01.01.2001	PREDATOR
REV.:	01.01.2005	
EQUIPEMENT <b>GRIZZLY</b> EQUIPMENT		340000

ITEM	NO.	QTY.	DESCRIPTION	ITEM	NO.	QTY.	DESCRIPTION
1	340001	1	FRAME	100	910107	4	BOLT, HEX.
2	340002	1	IDLER COVER	101	912002	4	WASHER
3	340003	1	BRAKE COVER	102	912502	4	LOCK-WASHER
4	340004	1	SHAFT	103	913005	12	NUT,HEX.
5	340005	1	CLUTCH HANDLE	104	910152	2	BOLT,HEX.
6	340006	1	DIFFERENTIAL	105	912003	7	WASHER
7	340007	1	SPROCKET	106	913507	2	LOCK-WASHER
8	340008	1	CLUTCH ROD	107	910356	11	BOLT, HEX.
9	340009	1	SPACER WASHER	108	913015	11	NUT, HEX.
10	935023	1	WHEEL,REAR	109	913511	3	LOCK-NUT
11	935019	1	WHEEL,FRONT	110	914214	2	COTTER PIN
12	340012	1	ENGINE COVER,W/SLIDDING DOOR	111	914649	2	COTTER PIN
13	340013	1	SWIVEL FORK	112	912007	4	WASHER
14	340014	1	SHAFT	113	912507	10	LOCK-WASHER
15	340015	2	SPACER	114	910102	4	BOLT,HEX.
16	340016	1	CHAIN	116	915301	8	NUT, HEX.
17	340017	1	TENSIONER PLATE, SPRING SIDE	117	910260	2	BOLT,HEX.
18	340018	1	SPACER WASHER	118	940161	2	SPRING LOCK PIN
19	340019	1	TENSIONER PLATE	119	910158	1	BOLT, HEX.
20	950200	1	ENGINE	120	913007	5	NUT,HEX.
22	341012	1	ENGINE COVER	121	910156	1	BOLT, HEX.
23	940007	2	HANDLE GRIP	122	912023	1	WASHER
24	940230	1	BRAKE BAND	123	914704	1	COTTER PIN
25	940240	1	BRAKE DRUM	124	910600	1	BOLT, HEX.
26	937011	1	SPRING	125	912000	1	WASHER
27	937007	2	SPRING	126	912500	1	LOCK-WASHER
28	923161	1	PILLOW BLOCK BEARING	127	913001	1	NUT,HEX.
29	923122	4	PILLOW BLOCK BEARING	128	910153	4	BOLT,HEX.
30	921138	1	PULLEY	130	910112	4	BOLT,HEX.
31	921172	1	PULLEY	131	913505	4	LOCK-WASHER
32	921402	1	PULLEY	132	934034	1	MASTER LINK
33	915008	2	SWIVEL	133	914905	2	HITCH PIN
34	921306	1	KEY				
35	936721	1	SPROCKET		340050		OPTION DOUBLE WHEEL
36	940180	1	THROTTLE CONTROL				
37	936111	1	SPROCKET				
38	370014	2	HUB ASSY.	51	341013	1	SWIVEL WHEEL
39	923342	4	SET COLLAR	52	341014	1	SHAFT
40	920104	1	BELT	53	935020	2	WHEEL,REAR
42	921308	3	KEY	122	912023	2	WASHER
43	921307	2	KEY	123	914704	2	COTTER PIN
62	330062	1	LEVER,BRAKE	134	914757	1	COTTER PIN

DATE:	01.01.2001	PREDATOR
REV.:	01.01.2005	
<b>EQUIPEMENT GRIZZLY EQUIPEMENT</b>		340000